

SYMBOLS

	Primary Cold Water, Supply
	Primary Cold Water, Return
	Secondary Cold Water, Supply
	Secondary Cold Water, Return
	Hot Water, Supply
	Hot Water, Return
	Direct Expansion System, Supply
	Direct Expansion System, Return
	Fire Suppression System, Supply
	Fire Suppression System, Return
CH	Chiller
EDX	Exterior Direct Expansion Unit
IDX	Interior Direct Expansion Unit
P	Pump
CRAH	Computer Room Air Handling Unit
R	Radiant Heater
BT	Buffer Tank
HX	Heat Exchanger

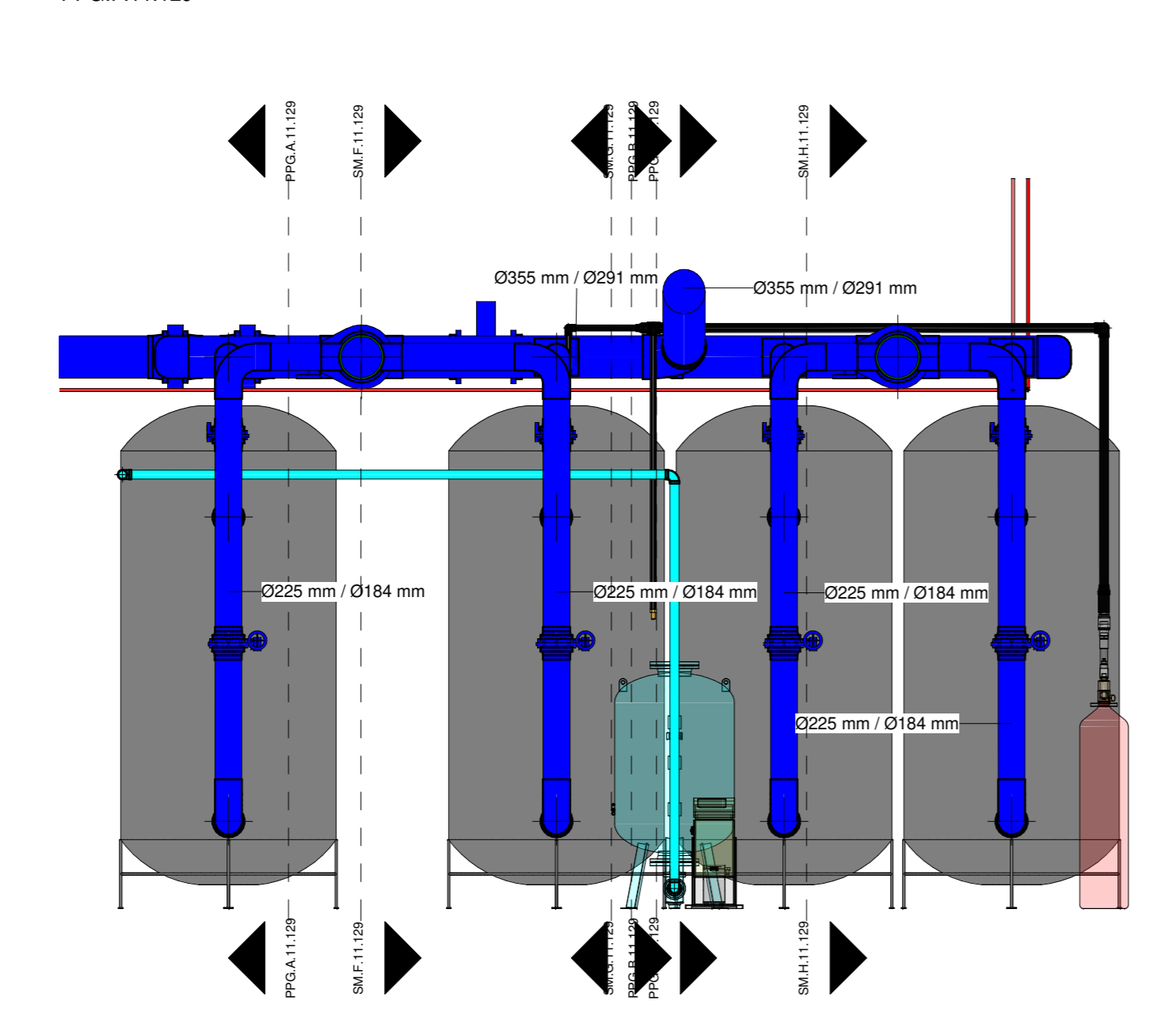
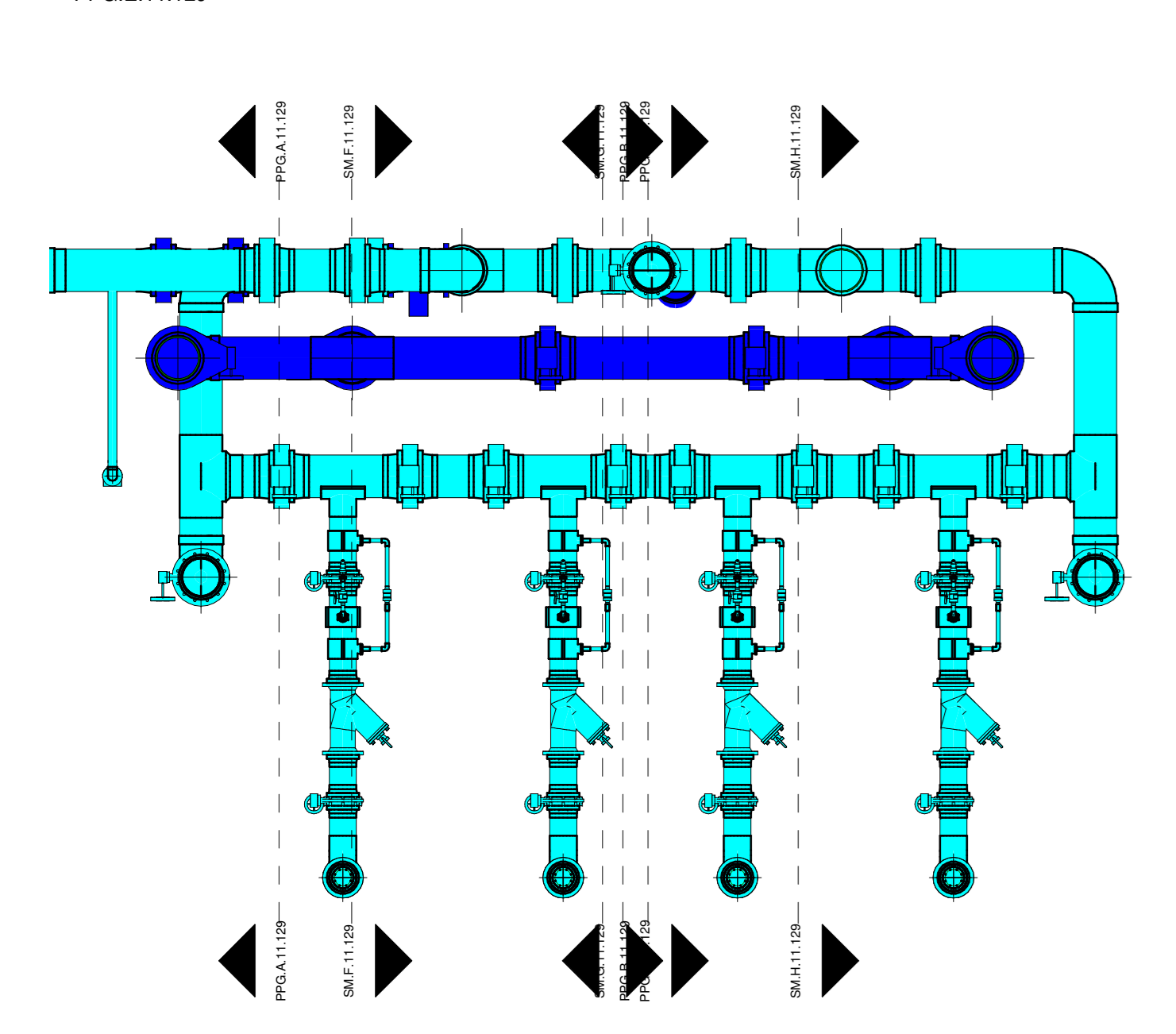
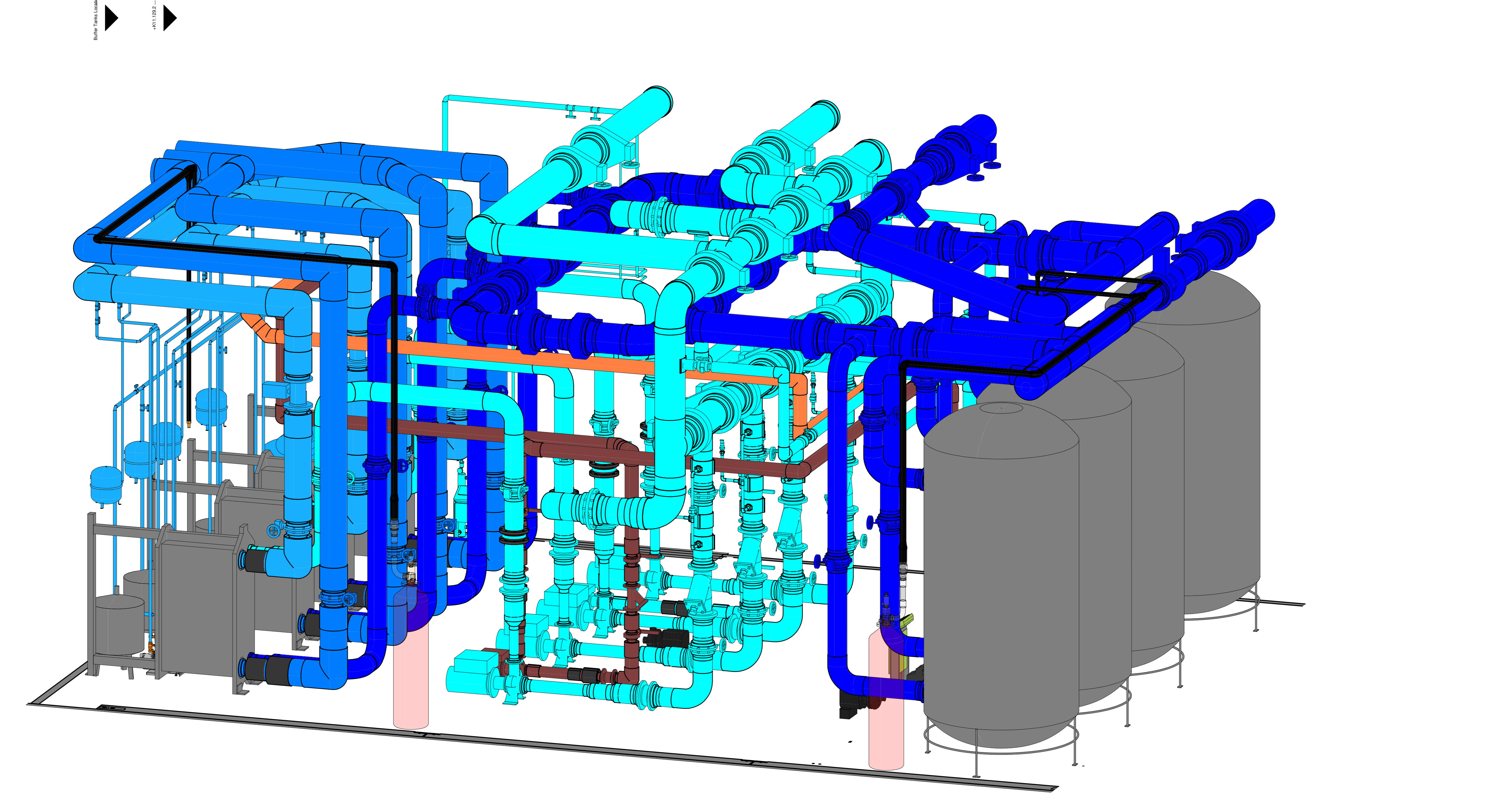
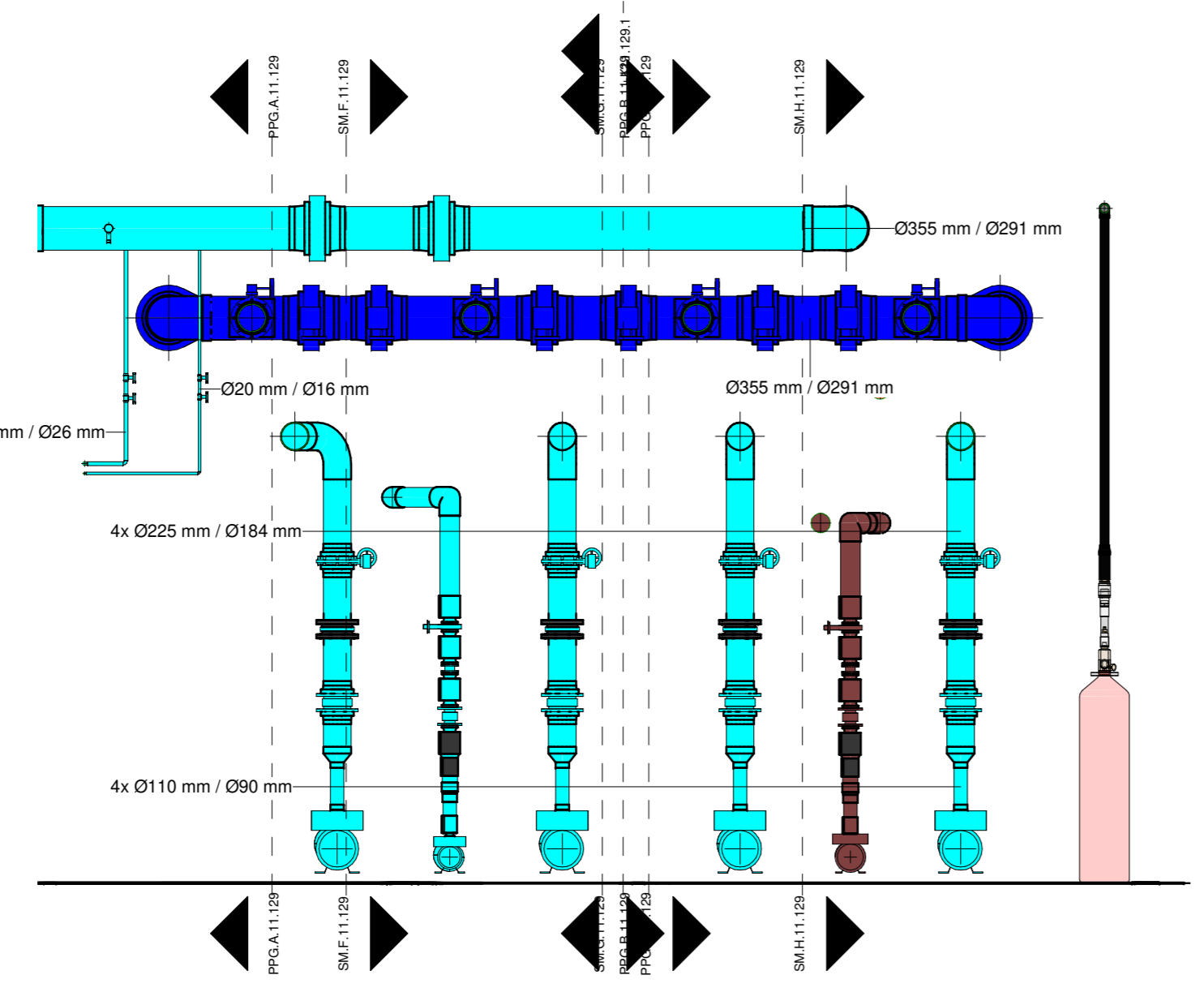
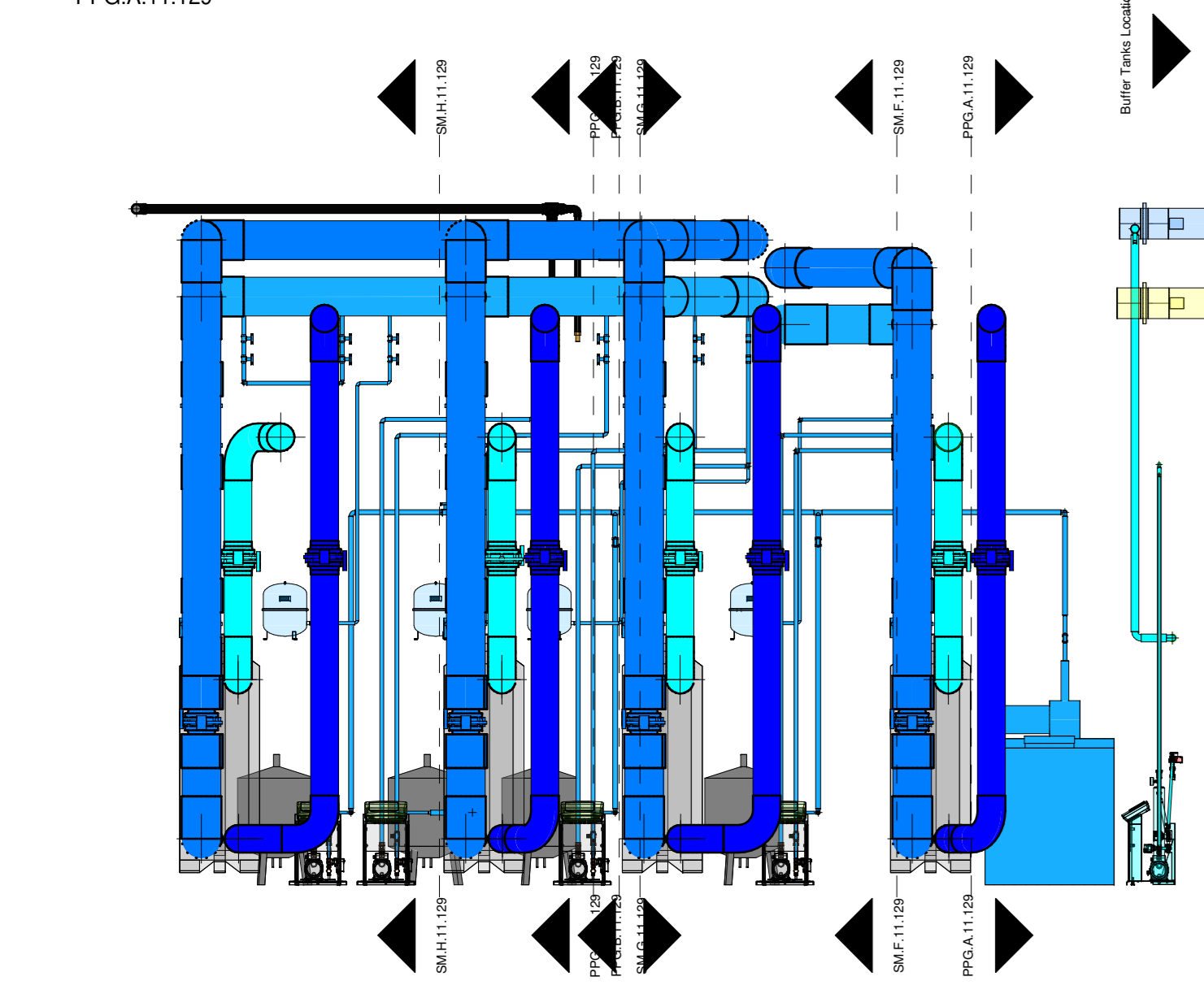
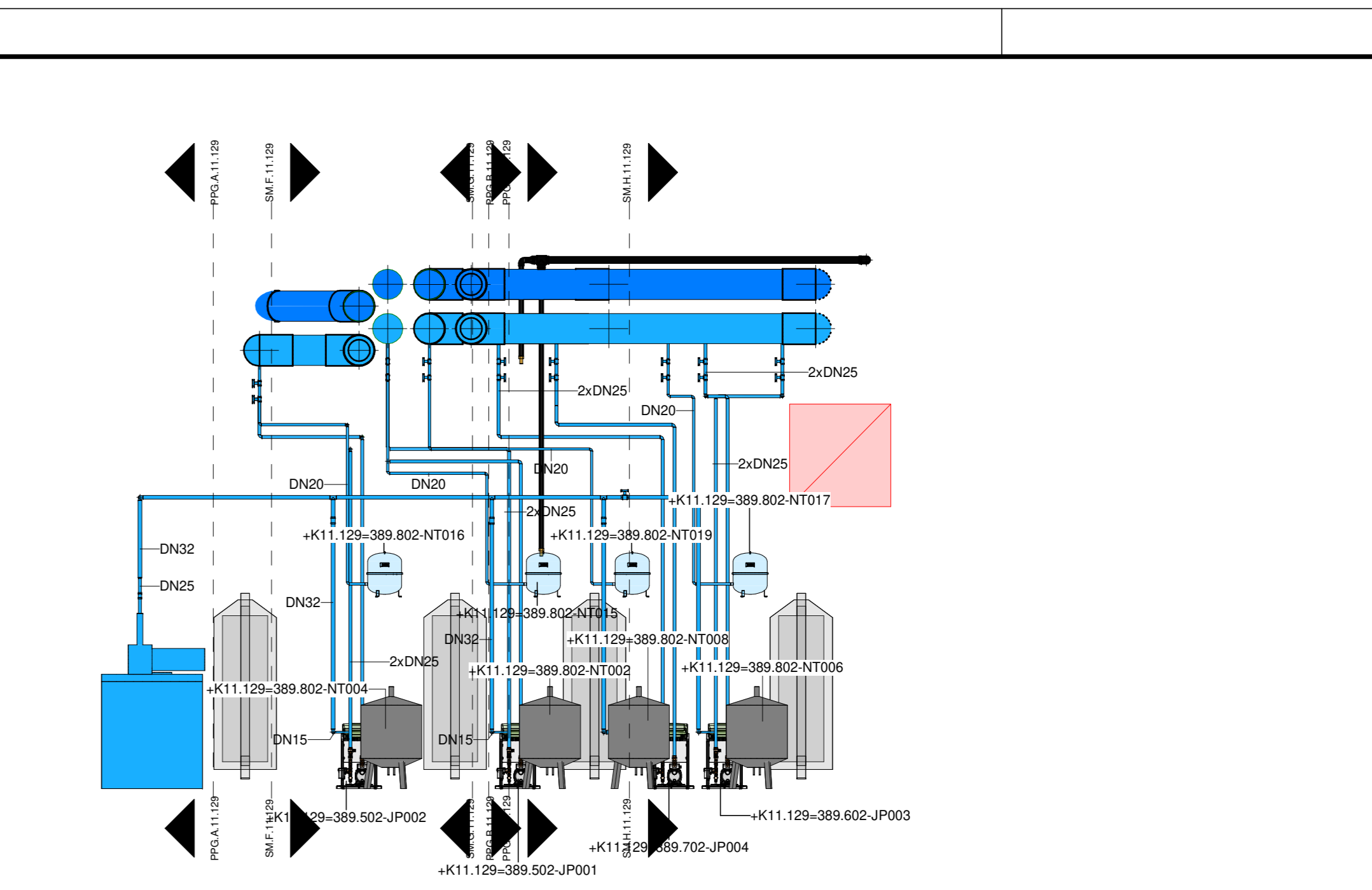
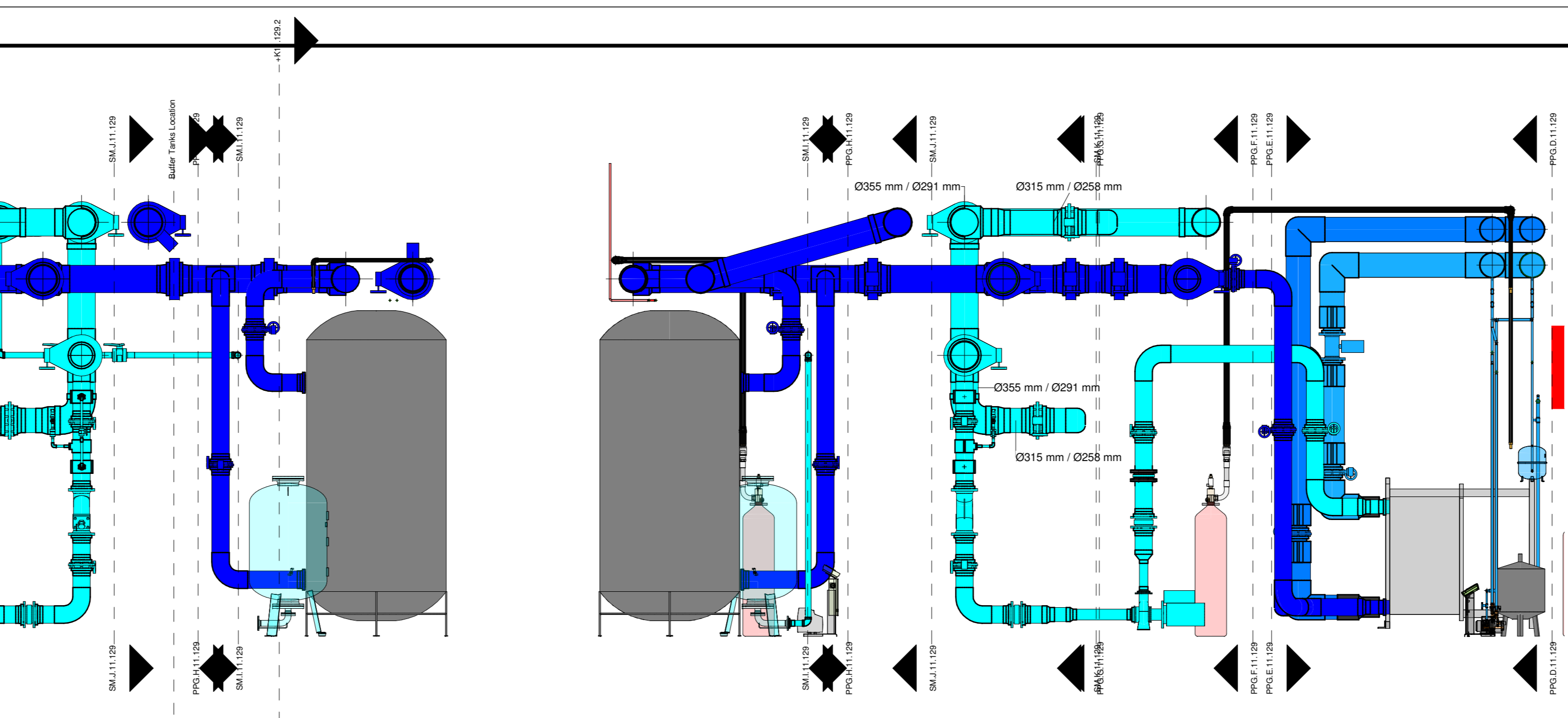
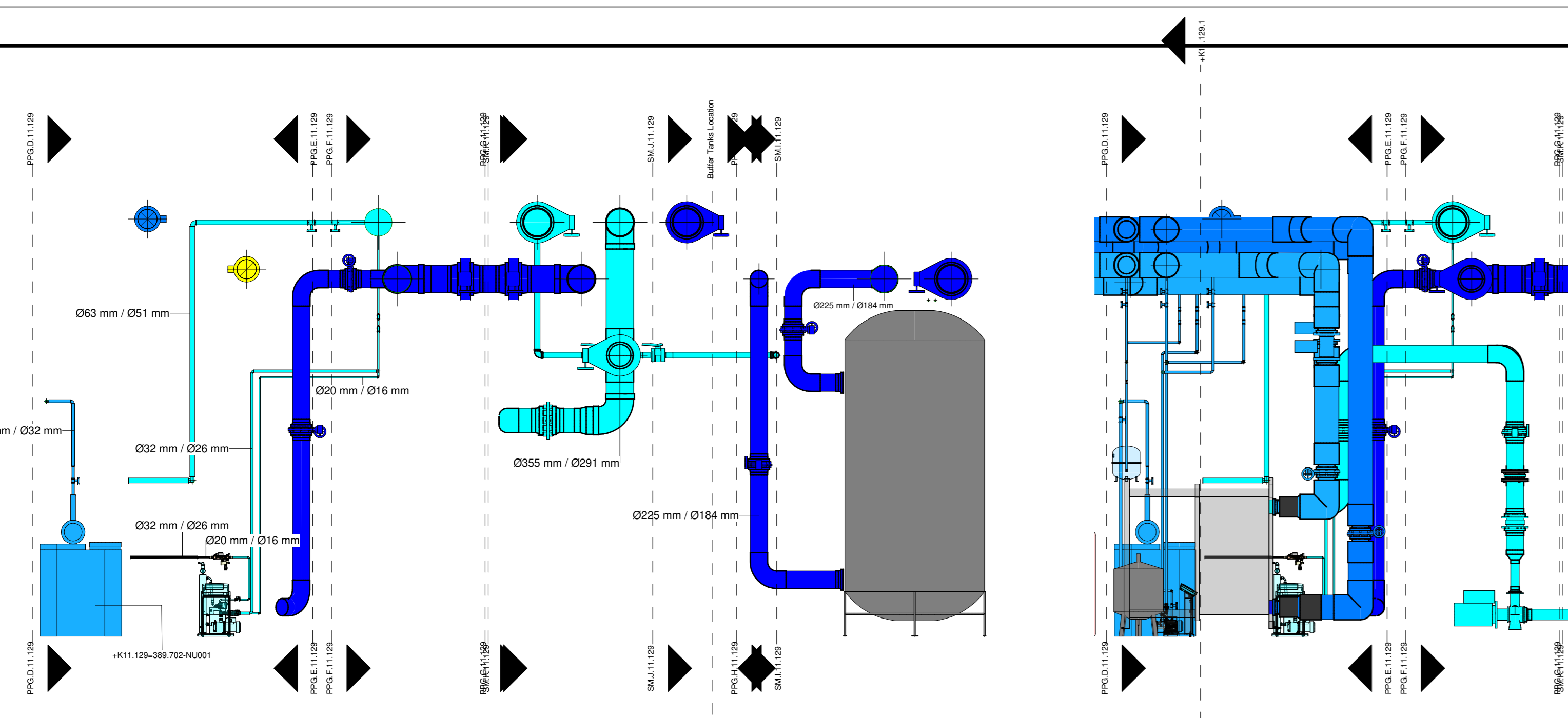

11.129 - 3D Room

DRAWING: KHVAC.PPG.11.D.2.C

C	2022.08.02	Chilled Water System revision.
B	2022.08.02	Verification and Chilled Water System revision. TH Code Change.
A	2022.08.01	Verification and Chilled Water System revision.
0		Issued for Construction.

ORIENTATION PLAN:

DESIGN & BUILD CONTRACTOR: CTS Nordics
ADDRESS: NAVITAS Nordics
ENGINEER: OLOF

CLIENT: Green Mountain

DESIGN COMPANY: NAVITAS Nordics

PROJECT: New DATA CENTER AT YTRE ET

DRAWING NAME: HVAC, Chilled Water System, Ground Floor, Pump Room, D

PROJECT: PPG.11.129	SCALE: 1:50	DATE: 2022.03.31	LAST REV: 2022.08.02	DATE: 2022.08.02	DATE: 2022.08.02	DATE: 2022.08.02	DATE: 2022.08.02
PROJECT: PPG.11.129	SCALE: 1:50	DATE: 2022.03.31	LAST REV: 2022.08.02	DATE: 2022.08.02	DATE: 2022.08.02	DATE: 2022.08.02	DATE: 2022.08.02
DRAWING: KHVAC.PPG.11.D.2.C	SCALE: 1:50	DATE: 2022.03.31	LAST REV: 2022.08.02	DATE: 2022.08.02	DATE: 2022.08.02	DATE: 2022.08.02	DATE: 2022.08.02

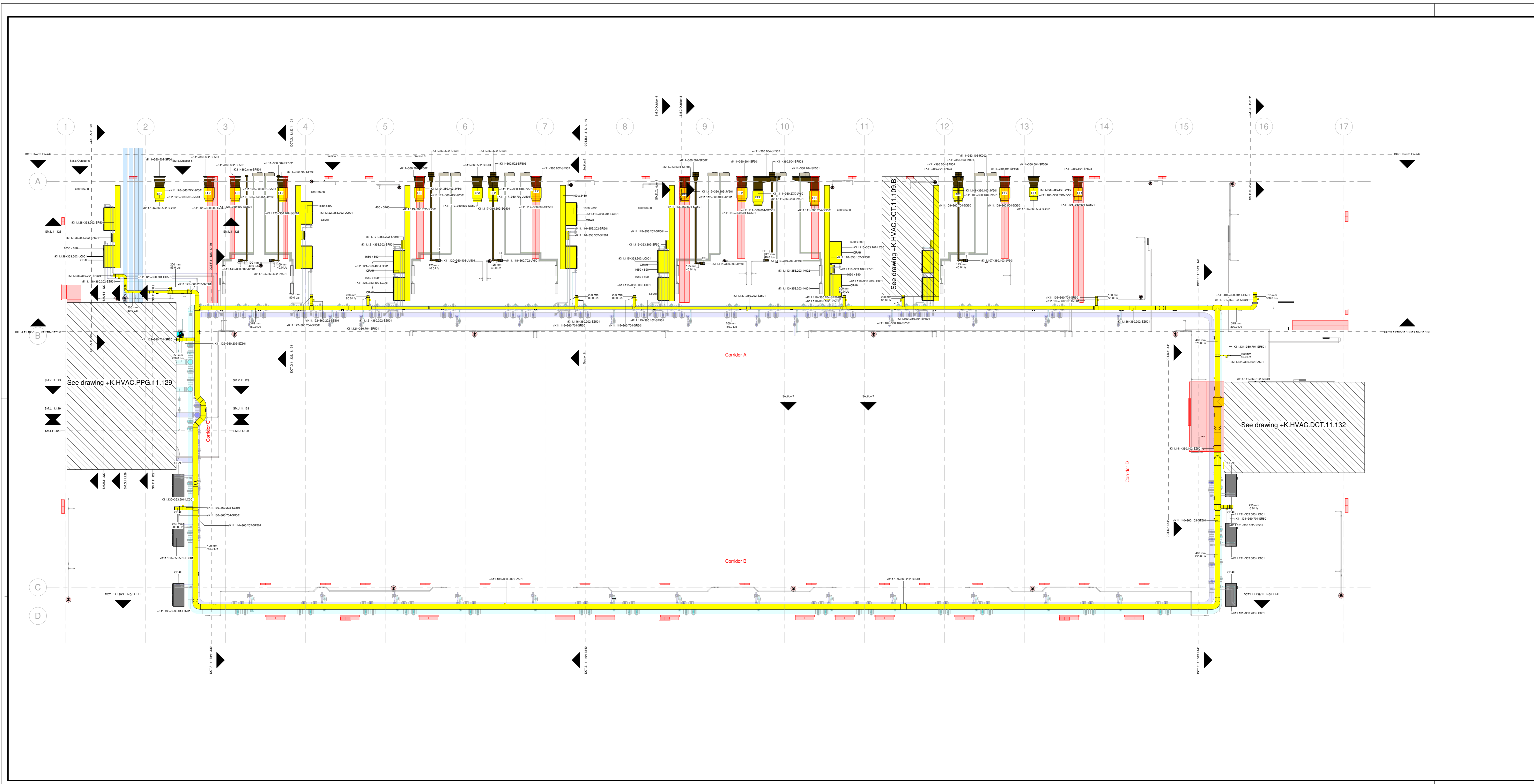

Intellectual Property by CTS Nordics AS. All Rights Reserved.

SYMBOLS

	Outdoor air duct - ODA
	Supply air duct - SUP
	Extraction air duct - ETA
	Exhaust air duct - EHA
	Fire resistant ductwork
	Air Handling Unit
	Exterior Direct Expansion Unit
	Interior Direct Expansion Unit
	Smoke Extraction Fan
	Extraction Fan
	Computer Room Air Handler

DRAWING: **KHVAC.DCT.11.2.E** REVISION: **E**

NO.	DATE	DESCRIPTION	BY	CHK
1	2022.03.31	TRV Control Revision, Ventilation System Design	JK	GL
2	2022.07.20	Ventilation System Design	JK	GL
3	2022.08.30	TRV Control Revision, Ventilation System Design	JK	GL
4	2022.08.30	Ventilation and Control System Design, TRV	JK	GL
5	2022.08.31	Ventilation and Control System Design, TRV	JK	GL

ORIENTATION PLAN:

DESIGN & BUILD CONTRACTOR: **CTS Nordics AS**
 ADDRESS: CTS Parkside AS, Engdalsveien 10B, 0651 OSLO

CLIENT: **Green Mountain**

DESIGN COMPANY: **NAVITAS Nordics AS**
 ADDRESS: NAVITAS Nordics AS, Engdalsveien 10B, 0651 OSLO

PROJECT: **New DATA CENTER AT YTRNE ENEBANK**

DRAWING NAME: **HVAC Air Duct Systems Ground Floor, Extraction Air Ducts**

PROJECT: Phase 1	PROJECT: 10111
DRAWING: ISSUED for Tender	SCALE: 1:100
DATE: 2022.03.31	LAST REV: 2022.08.30
DRAWING: KHVAC.DCT.11.2.E	FORM: A text
	REVISION: E

2022.03.31

